

SERIE DE 10 3.3.1.06.

Distributore Idraulico Tipping Valve

CODICE DI ORDINAZIONE - DECODING

3.3.1.06 . X . X . X . XX . X

DE 10/6
DE 10/7

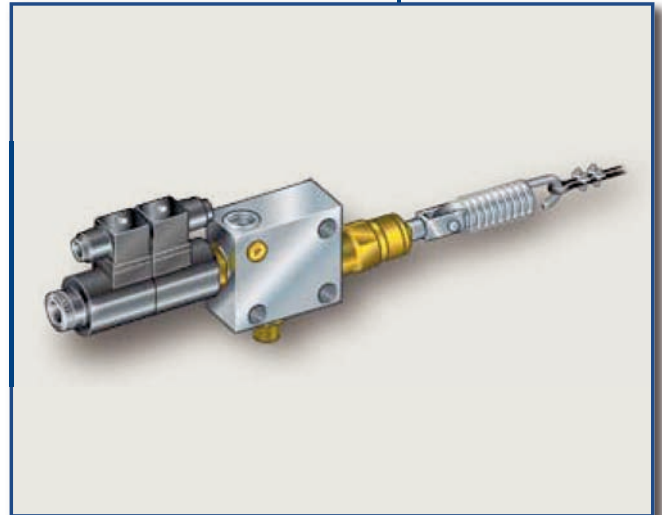
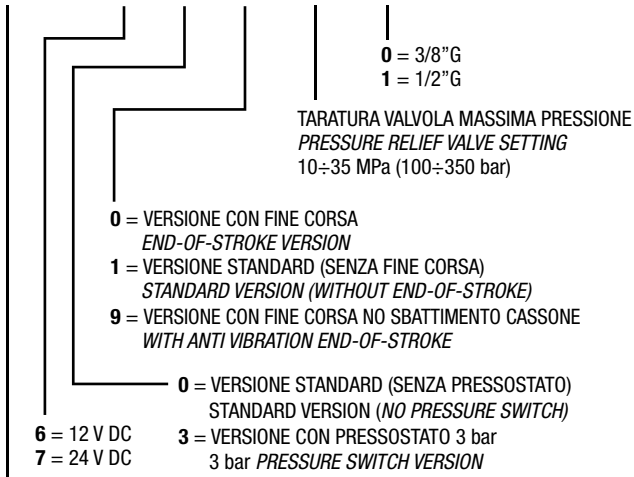

CODICE BASE/BASIC CODE

CARATTERISTICHE E DATI TECNICI - SPECIFICATIONS AND TECHNICAL DATA

VERSIONE STANDARD (senza fine corsa) STANDARD VERSION (without end-of-stroke)	
Portata massima Flow max	25 l/min
Pressione massima di lavoro Max working pressure	315 bar

VERSIONE (con fine corsa) VERSION (with end-of-stroke)	
Portata massima Flow max	15 l/min
Pressione massima di lavoro Max working pressure	200 bar

CARATTERISTICHE COMUNI GENERAL SPECIFICATIONS			
Pressione massima di picco (resistenza allo scoppio) Max peak pressure (bursting strength)		475 bar	
Campo viscosità Viscosity range	12-100 cSt	Filtrazione/Filtering ISO 4406 $\beta_x=75$	20/17 25 μm
Pressione massima su T Max pressure on the T	30 bar	Peso Weight	1.9 kg
Temperatura fluido °C (t) Fluid temperature °C (t)	-25° +80° C	Fluido olio minerale Mineral oil	ISO VG 46

- > Distributore elettrico da 25 l/min per veicoli ribaltabili con sola motrice.
- > Consente la **salita** e la **discesa**.
- > In posizione di riposo la mandata ricircola a serbatoio e l'utenza **A** è chiusa.
- > Sono incorporate le **valvole di ritegno e controllo pressione in P**.
- > Flangiabile a **serbatoio**.
- > **Pressostato e/o tirante per fine corsa** A RICHIESTA (vedi codifica).

- > Electrical operated 25 l/min distributor for tipping vehicles with tractor only.
- > It allows **tipping and lowering**.
- > In neutral position the oil outlet is open to oil tank and the port **A** is closed.
- > Port **P** check and adjustable **relief valves** are included.
- > Flange connection to **tank**.
- > **Pressure switch** and/or **end-of-stroke rope** ON REQUEST (ordering code).

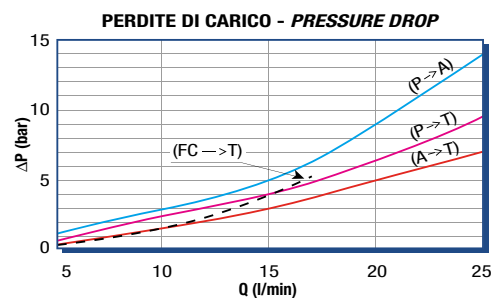
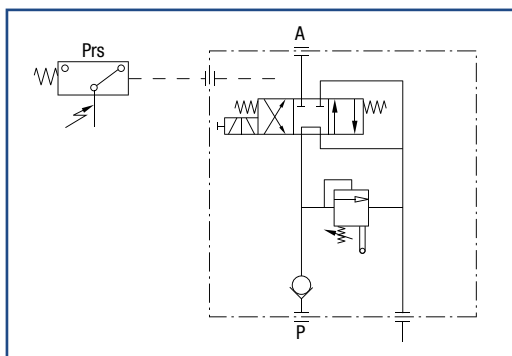

RILIEVI ESEGUITI CON OLIO ISO VG 46 A 50° C ($\nu=30$ cSt)
 THE ABOVE SPECIFICATIONS REFER TO OIL TYPE ISO VG 46 AT 50° C ($\nu=30$ cSt)

VERSIONE STANDARD SENZA FINE CORSA
STANDARD VERSION WITHOUT END-OF-STROKE

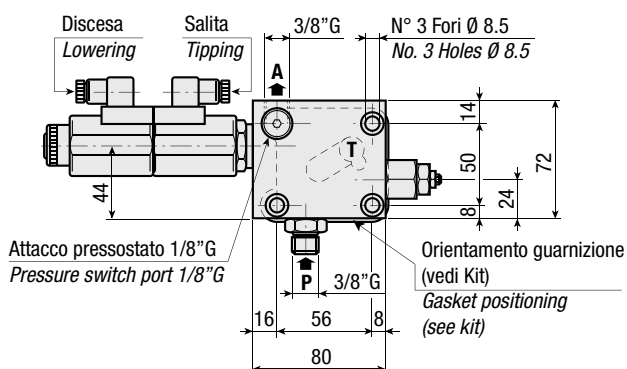
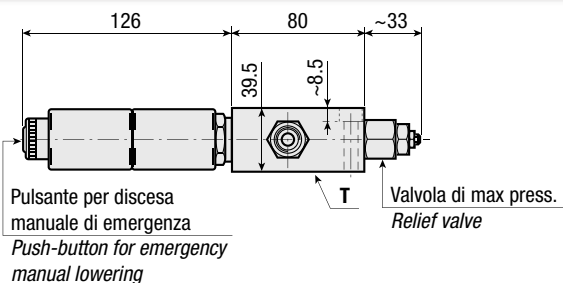

VERSIONE CON FINE CORSA
VERSION WITH END-OF-STROKE

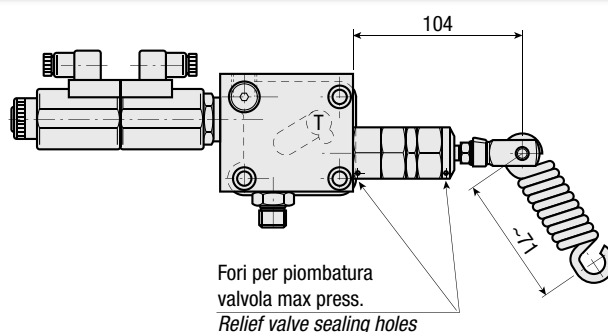

DESCRIZIONE - DESCRIPTION	CODICE - CODE
Pressostato - Pressure switch	0.99.00.338.000

Pressostato con guarnizione
Coppia di serraggio: 30 ± 5 Nm
Pressure switch with washer
Tightening torque: 30 ± 5 Nm

DESCRIZIONE - DESCRIPTION	CODICE - CODE
Kit per fissaggio al telaio - Stud kit for frame mounting	2.05.647.00000

KIT PER FISSAGGIO AL SERBATOIO - STUD KIT FOR TANK MOUNTING

DESCRIZIONE - DESCRIPTION	CODICE - CODE
Per serbatoio metallico 10 lt - For 10 lt steel tank	2.16.045.00000
Per serbatoio metallico 15 lt - For 15 lt steel tank	2.16.049.00000
Per serbatoio in plastica 10 lt - For 10 lt plastic tank	2.16.035.00000
Per serbatoio in plastica 15 lt - For 15 lt plastic tank	2.16.060.00000

