

### DIN 5462 SE

CODICE DI ORDINAZIONE / ORDERING CODE

# 200 FZH XXX X S

**DIN 5462 SE**  
 ROTAZIONE / ROTATION  
**D** = DESTRO / CLOCKWISE  
**S** = SINISTRO / ANTICLOCKWISE  
 CILINDRATA / DISPLACEMENT  
 TIPO / TYPE  
 POMPA AD INGRANAGGI / GEAR PUMP

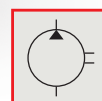
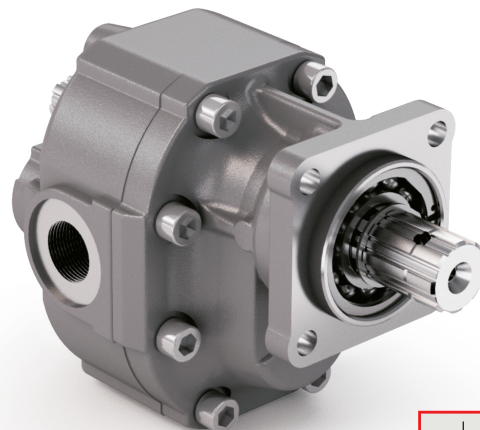

1

**FZH 75**

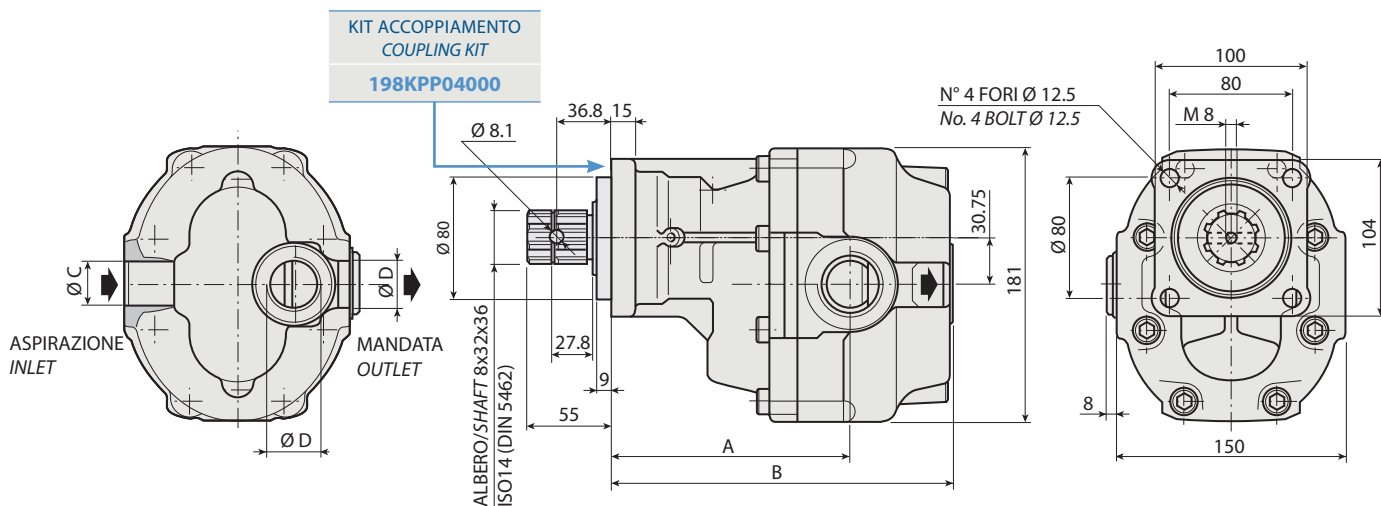

#### CARATTERISTICHE E DATI TECNICI / SPECIFICATIONS AND TECHNICAL DATA

TIPO TYPE	CODICE / CODE		CILINDRATA DISPLACEMENT	A	B	C	D	PESO WEIGHT
	ROTAZIONE DESTRA CLOCKWISE ROT.	ROTAZIONE SINISTRA ANTICLOCKWISE ROT.	cm <sup>3</sup> /rev.	mm	mm	ASPIRAZIONE INLET	MANDATA OUTLET	kg
<b>FZH 75</b>	<b>200FZH075DS</b>	<b>200FZH075SS</b>	<b>73</b>	<b>127.5</b>	<b>194.5</b>	<b>1" ¼ G</b>	<b>1" G</b>	<b>18</b>

KIT RASAMENTI / THRUST PLATES KIT CODICE / CODE 2H451075000

KIT GUARNIZIONI COMPLETO / COMPLETE SEALS KIT CODICE / CODE 21901500000

Per la scelta dei raccordi orientabili vedi pag. 212-213 / For the selection of adjustable fittings see page 212-213

- A richiesta possono essere fornite le pompe ad ingranaggi con le guarnizioni HNBR per climi freddi (-40 °C).
- On request our gear pumps may be supplied with HNBR seals for cold climates (-40 °C).

**DIN 5462 SE**

TIPO / TYPE			FZH 75
Cilindrata <i>Displacement</i>	Vg	cm <sup>3</sup> /n cm <sup>3</sup> /rev.	73
Pressione massima continua <i>Max continuous operating pressure</i>	P1		300
Pressione massima intermittente <i>Max intermittent operating pressure</i>	(max 30 s) P2	bar	320
Pressione massima di picco <i>Max peak pressure</i>	(≤ 0.1 s) P3		450
Velocità massima intermittente <i>Max intermittent speed</i>	(P ≤ 20 bar) n3		3800
Velocità massima continua <i>Max continuous speed</i>	(≤ P1) n1	n/min r.p.m.	1800
Velocità minima intermittente <i>Min intermittent speed</i>	(≤ P2 x 0.5) (max 30 s) n4		300

1

DIAGRAMMI / DIAGRAMS

**POTENZA ASSORBITA**  
**POWER INPUT**

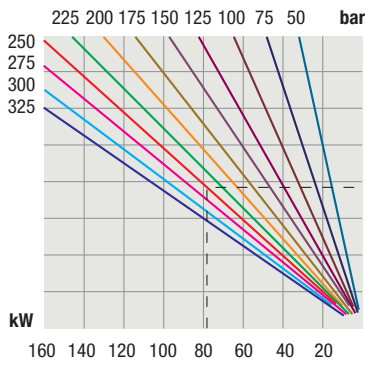

**PORTATA**  
**CAPACITY**

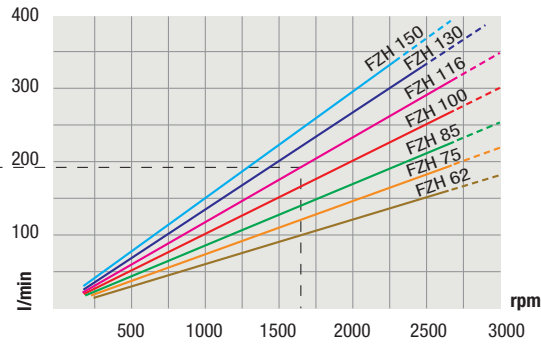

**RENDIMENTO VOLUMETRICO**  
**VOLUMETRIC EFFICIENCY**

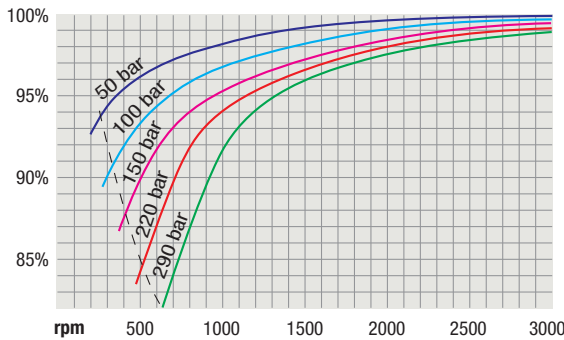

**COPPIA ASSORBITA**  
**DRIVE TORQUE**

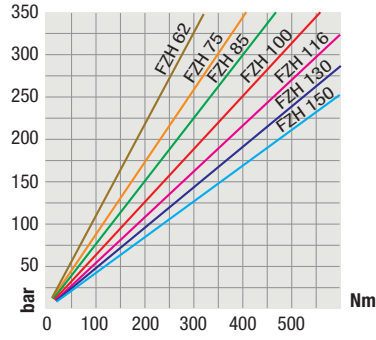

RILIEVI ESEGUITI CON OLIO ISO VG 46 A 50° C ( $\nu = 30$  cSt)  
THE ABOVE SPECIFICATIONS REFER TO OIL TYPE ISO VG 46 AT 50° C ( $\nu = 30$  cSt)