

# SERIE P1-3F 3.1.6.1.

CODICE DI ORDINAZIONE / DECODING

3.1.6 . 1 . XXX . 1 . 0 . 00

**UNI** P1 25-3F  
21-222

1 = UNI 3 FORI/3 HOLES UNI

CILINDRATA/DISPLACEMENT

1 = SERIE NORMALE/STANDARD SERIES

CODICE BASE/BASIC CODE

**Pompa a Pistoni**  
*Piston Pump*

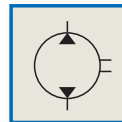

## CARATTERISTICHE E DATI TECNICI / SPECIFICATIONS AND TECHNICAL DATA

TIPO TYPE	CODICE CODE	CILINDRATA DISPLACEMENT cm <sup>3</sup> /rev.	A mm	B mm	C mm	D mm	E ASPIRAZIONE INLET	F MANDATA OUTLET	PESO WEIGHT kg
P1 25-3F	3.1.6.1.025.1.0.00	25	253	113	106	138	1" 1/4 G	1" G	10.0

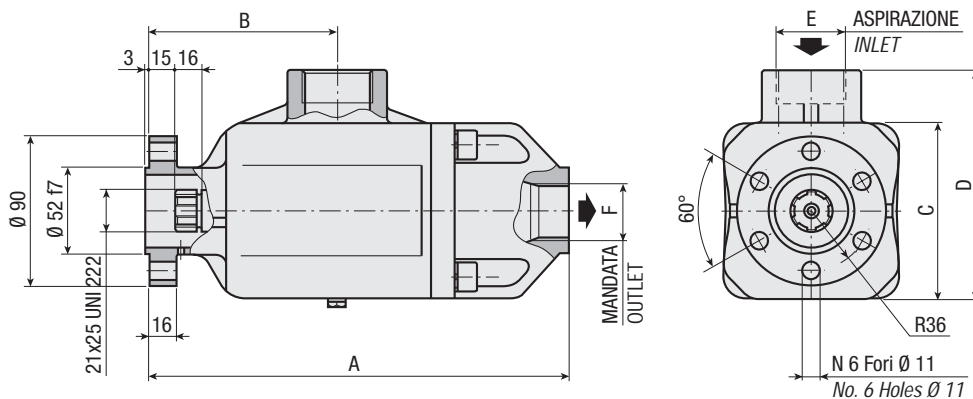

**DATI TECNICI / TECHNICAL DATA**

**ESEMPIO CICLI LAVORO / EXAMPLE OF WORKING CYCLES**

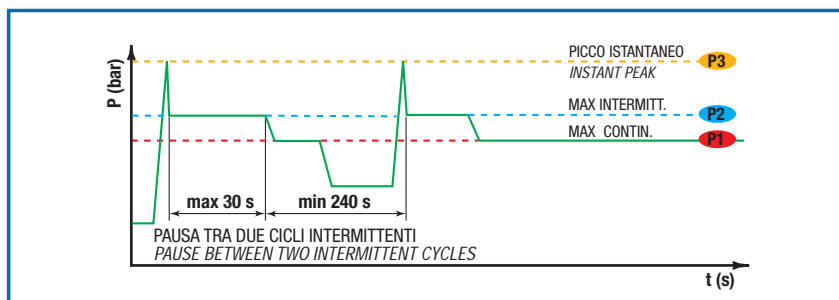

Pressione d'aspirazione: <i>Inlet pressure:</i>	0.7 ÷ 1.5 bar (assoluti/absolute)
Campo viscosità lavoro: <i>Operating viscosity range:</i>	12 ÷ 100 cSt
Temperatura fluido °C (t): <i>Fluid temperature °C (t):</i>	-10° + 80° C

Pressione Lavoro <i>Working Press.</i>	P2	Contaminazione / <i>Contamination</i>		Filtro / <i>Filter</i> βx = 75
		NAS 1638	ISO 4406	
≤ 200 bar		12	21/18	40 μm
≥ 200 bar		11	20/17	25 μm

◀ **FILTRAZIONE CONSIGLIATA (ritorno o mandata)**  
*RECOMMENDED FILTERING (return or outlet)*

TIPO / <i>TYPE</i>			
Cilindrata <i>Displacement</i>		Vg	cm <sup>3</sup> /n cm <sup>3</sup> /rev.
Pressione massima continua <i>Max continuous operating pressure</i>		P1	bar
Pressione massima intermittente <i>Max intermitt. operating pressure</i>	(max 30 s)	P2	
Pressione massima di picco <i>Max peak pressure</i>	(≤ 0.1 s)	P3	
Velocità massima intermittente <i>Max intermittent speed</i>	(P ≤ 20 bar)	n3	n/min r.p.m.
Velocità massima continua <i>Max continuous speed</i>	(≤ P1)	n1	
Velocità minima intermittente <i>Min intermittent speed</i>	(≤ P2 x 0.5) (max 30 s)	n4	

P1 25-3F
25
350
400
450
2200
1800
400

**DIAGRAMMI / DIAGRAMS**

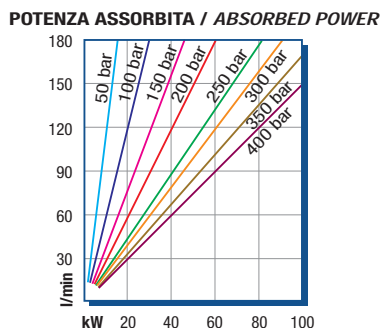
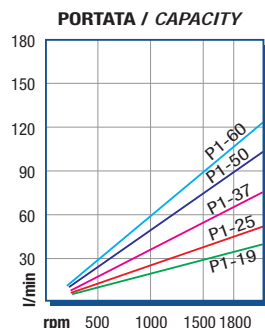

RILIEVI ESEGUITI CON OLIO  
ISO VG 46 A 50° C (ν=30 cSt)  
THE ABOVE SPECIFICATIONS  
REFER TO OIL TYPE ISO  
VG 46 AT 50° C (ν=30 cSt)

SERIE P1-3F 316.1.

POMPE A PISTONI PISTON PUMPS

