



www.hydrocar.com



www.munciepower.com



www.pzbitaly.com



www.takarada.com.br



www.hspenta.it



Santiago Del Chile  
Concepción  
Antofagasta  
www.hydrocar.cl



Hosur (Tamil Nadu)  
Rudrapur (Uttarakhand)  
www.interpumphydraulicsindia.com



Wuxi (Jiangsu)  
www.iph.net.cn



Jabel Ali (Dubai)  
www.interpump.ae



Brie Comte Robert (Paris)  
Flévy (Metz)  
www.interpumphydraulics.com



Lima  
www.interpumphydraulics.com



Meinerzhagen (Nordrhein-Westfalen)  
www.interpumphydraulics.com



Kingswinford West Midlands (England)  
www.interpumphydraulicsuk.com



**EFP-3**

Engine Flywheel P to SAE 3

**New**

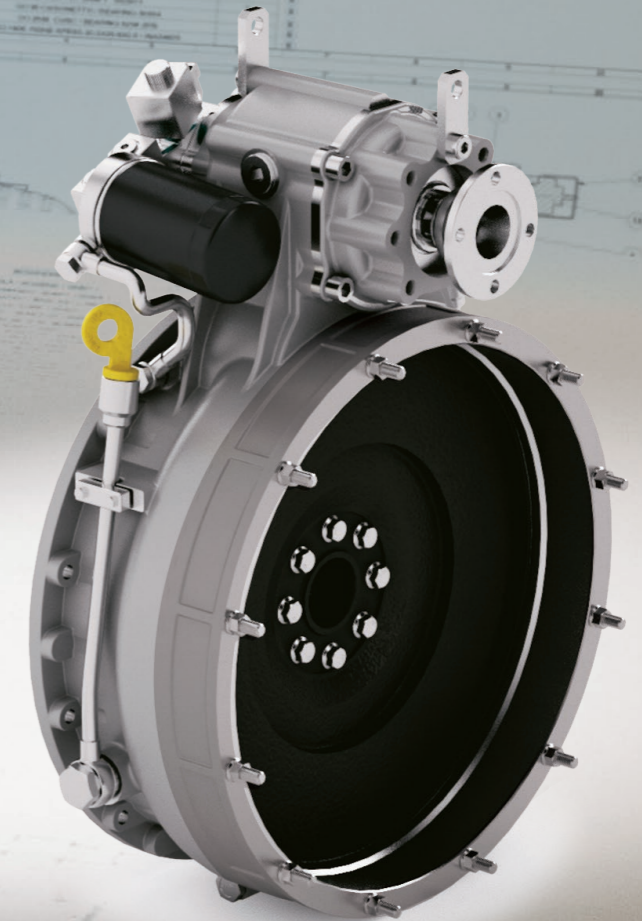

Layout & Graphic Design: Studio '80 (BO) ITALY



### PTO FOR HEAVY DUTY APPLICATIONS (100% OF ENGINE AVAILABLE TORQUE)

Main applications are:

- fire-fighting (including pump & roll function),
- sewer cleaner,
- snowplough,
- refrigerator (cooler) vehicle,
- other.

### EASY TO FIT

The PTO EFP-3 is so easy to adapt that is easily suitable to be installed onto the following transmissions (manual, automated and fully automatic) and related engines:

- IVECO (special flange),
- ZF,
- ALLISON (series 2000),
- EATON,
- DAIMLER (special flange),
- TATA,
- ISUZU,
- HINO,
- NISSAN,
- FUSO,
- HYUNDAI,
- other.

### TECHNICAL SPECIFICATIONS

PTO clutch engagement limit conditions:

1000 r.p.m. / 400 Nm / 42 kW
1500 r.p.m. / 267 Nm / 42 kW
2000 r.p.m. / 200 Nm / 42 kW

PTO output Torque:

400 Nm / ratio 1:1,02
320 Nm / ratio 1:1,27
270 Nm / ratio 1:1,56

The max Power has to be considered as continuous use (63 kW max).

### FUNCTIONS

- Engine dependent pto;
- pto usage both with standing still vehicles as well as in mobile conditions (pump and roll);
- pto mounting position between engine and gearbox;
- pto output at 12 O'clock (from 11 up to 1 O'Clock - see pictures);
- assembling without any "special" or dedicated tool.

### OPTIONS

- Pto output engagement control, hot-shift (clutch), constant drive and hydraulic shifting (engine off);
- pre-arrangement for external oil cooler;
- temperature control option;
- oil level inspection;
- pto output sensor speed;
- oil cooler (air/oil);
- no residual clutch drag (active brake function).

### TECHNICAL SPECIFICATIONS

Unit through torque (to rear axle):

- as indication and reference 500 Nm (max.); 163 kW - 220 HP (max).

### VEHICLES INSTALLATIONS

Max. engine speed:

3100 r.p.m

Max. operating angle of the vehicle: - forward / rearward: 17° (30%),

- right / left: 17° (30%).

### FLANGE OUTPUT

- PTO output:
- pump ISO 7653 4 bolts,
  - pump SAE B-BB 2-4 bolts,
  - flange DIN 100-120 (XS),
  - flange SPICER 1300-1410 (XS),
  - flange 120 ISO 8667 (XS).

### MOUNTING POSITIONS

STANDARD: h12

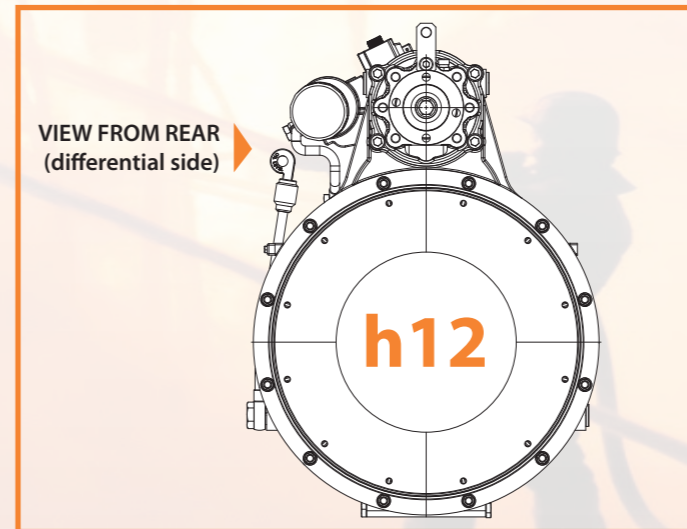

OPTIONAL: +30° or -30°

(for other inclinations, please contact our Technical Dept.)

