



SPLIT SHAFT POWER TAKE-OFF 210 KGM

4.2.58.9.X.03.2.0



- For fitment in the drive shaft between the gearbox and the rear axle in vehicles up to about 120 BHP.
- Throughput torque: 210 Kgm.
- SAE 6 bolt openings to accept up to two side PTOs to drive heavy duty auxiliary equipment.
- Wide selection of PTOs available. PTO ratio and output option can be different for each side.
- Up to four outputs possible - two to the front, two to the rear.
- Each side PTO can be shifted in and out of gear independently by air or cable.
- Auxiliary power can be transmitted whilst the vehicle is in motion.
- Main drive to the rear axle is controlled by air or cable independently of PTO operation.

DRY WEIGHT: 11,8 kg

4.2.58.9.X.03.2.0

BASIC SERIAL NUMBER _____

SHIFTING
1 = AIR
2 = CABLE

AUXILIARY POWER TAKE-OFFs SELECTION

PTO output speed depends on selected gear in gearbox, PTO ratio, engine r.p.m.

Select the required PTO ratio and power output.

When using one only side PTO the cover kit part nr. 2.99.023.0000 must be requested to close the free aperture.

PTO	RATIO	TORQUE Kgm	ROTATION	STUD KIT
4.2.31.5.X.XX.X.X	0.869	40	ENGINE	2.05.009.0000
5.2.69.1.X.XX.X.X	0.921	25	ENGINE	2.05.117.0000
5.3.69.1.X.XX.X.X	1.366	25	ENGINE	2.05.117.0000
4.2.15.4.X.XX.X.X	1.765	20	ENGINE	2.05.121.0000
5.4.69.1.X.XX.X.X	1.667	20	ENGINE	2.05.117.0000

SECTION A-A

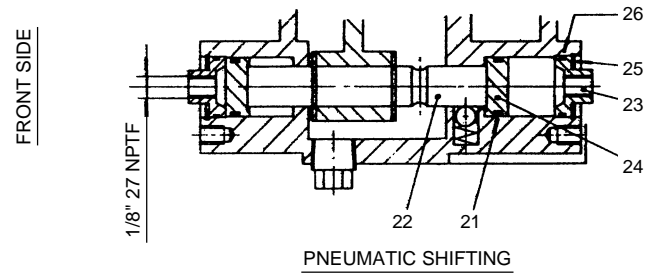
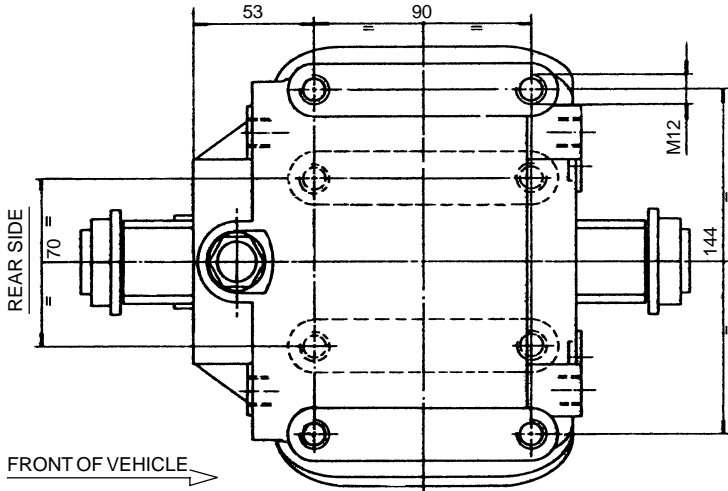
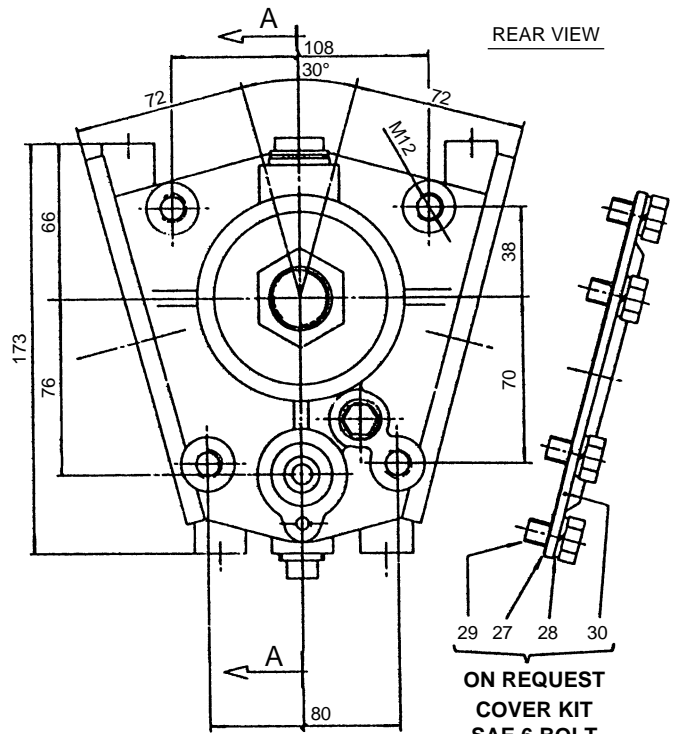
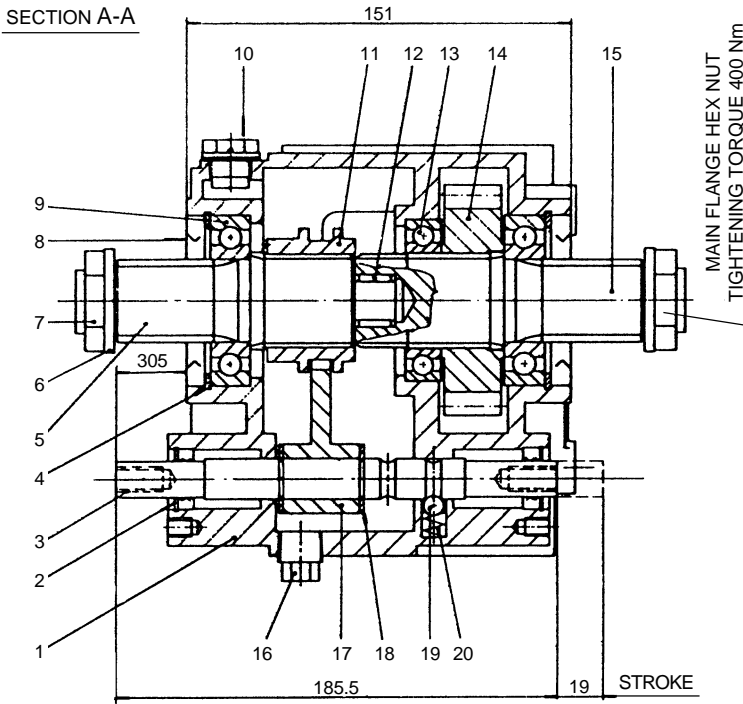

REF.	CODE	DESCRIPTION	QT.
1	1.01.05.009.00	Housing	1
2	0.08.01.004.00	Seal 15x26x7	2
3	1.14.03.069.00	Shaft	1
4	0.07.02.015.00	Circlip 72i UNI 7437	2
5	1.13.01.123.00	Shaft	1
6	0.04.01.005.00	Washer diam. 25,1x45x4 FE370	2
7	1.30.02.004.00	Hex nut 206E/38	2
8	0.08.01.067.00	Seal 50x72x8	2
9	0.10.01.012.00	Bearing 6207	2
10	0.12.01.038.00	Filler-breather with gasket TCSF 1815	1
11	1.17.01.036.00	Splined sleeve	1
12	0.10.06.001.00	Needle cage K16x22x16	1
13	0.10.01.008.00	Bearing 6008	1
14	1.11.03.131.00	Gear 30 T	1
15	1.13.01.124.00	Shaft	1
16	0.12.01.049.00	Plug M18x1,5 FIAT 1/43236/11	2

REF.	CODE	DESCRIPTION	QT.
17	1.22.01.040.00	Fork	1
18	0.07.03.001.00	Circlip RS15 UNI 7434	2
19	0.11.01.002.00	Ball 3/8"	1
20	1.28.01.003.00	Coil spring mod.15/2	1
21	0.08.02.014.00	O-Ring OR 3081	2
22	1.14.03.068.00	Shaft	1
23	1.24.01.067.00	Cover	2
24	1.21.02.016.00	Piston	2
25	0.07.02.034.00	Circlip 26i UNI 7437	2
26	0.08.02.067.00	O-Ring OR 2087	2
ON REQUEST: COVER KIT SAE 6 BOLT 2.99.023.0000			
27	1.29.01.501.00	Gasket 6F SAE sp. 0,5	1
28	0.04.02.003.00	Lockwasher 10,5 UNI 1751	6
29	0.01.01.014.00	Capscrew TE M10x30 UNI 5739	6
30	0.99.00.409.00	Cover 6 bolt SAE	1

ON REQUEST: MOUNTING BRACKET KIT CODE 2.99.197.0000

Mounting kits are available for easy installation of the 4.2.58.9 Split-Shaft Units in the truck chassis.

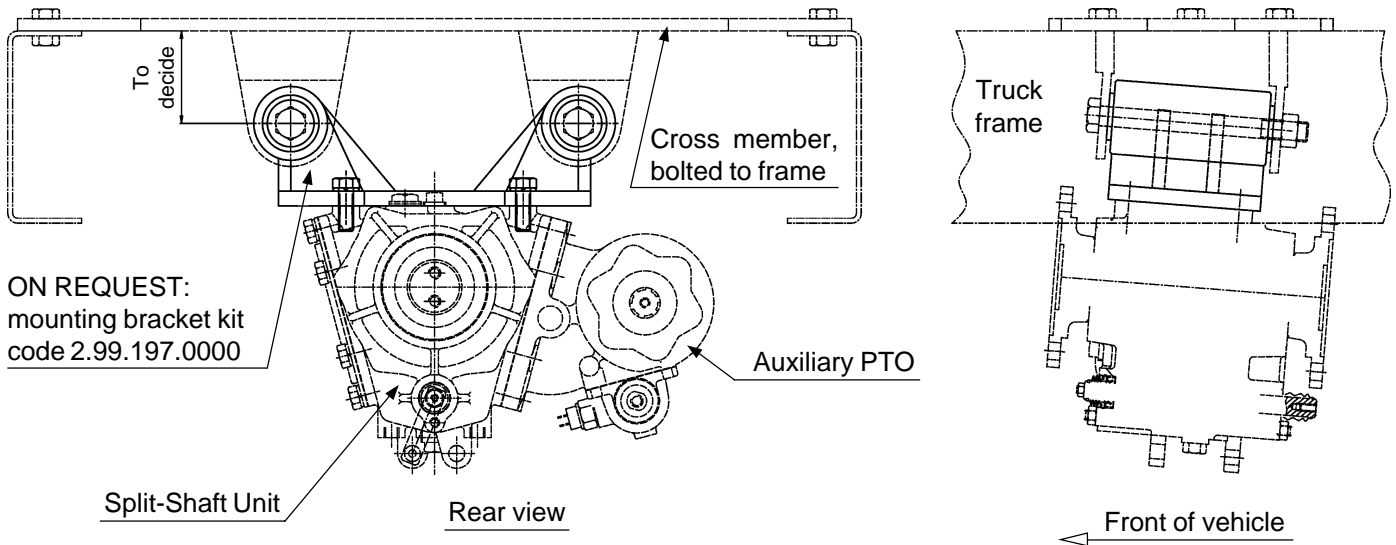

ON REQUEST:
mounting bracket kit
code 2.99.197.0000

ON REQUEST:

**DOUBLE-ACTING AIR CONTROL TO CONNECT/DISCONNECT MAIN DRIVE
CODE 0.00.04.023.00**

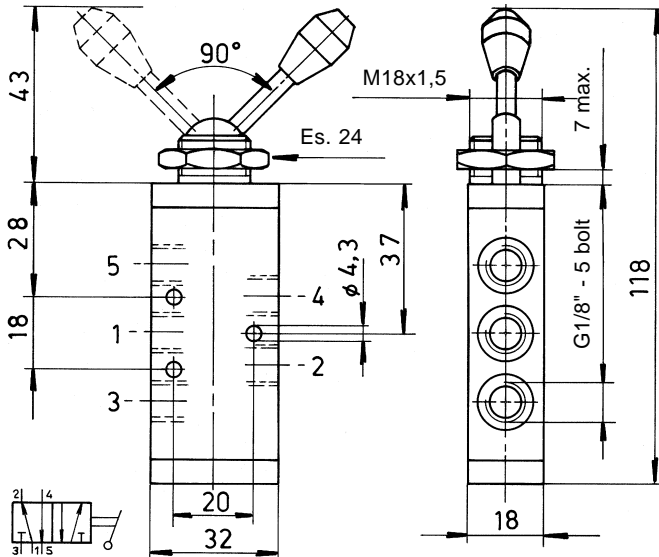

SPECIFICATIONS

Fluid:	Air, filtered and oiled
Operating pressure:	10 Bar max.
Operating temperature:	from -5°C to +70°C