



SPLIT SHAFT POWER TAKE-OFF 400 KGM

4.2.58.0.X.03.0.0



- For fitment in the drive shaft between the gearbox and the rear axle in vehicles up to about 160 BHP.
- Throughput torque: 400 Kgm.
- Compact design with aluminium casing keeps weight to a minimum.
- SAE 6 bolt openings to accept up to two side PTOs to drive heavy duty auxiliary equipment.
- Wide selection of PTOs available. PTO ratio and output option can be different for each side.
- Up to four outputs possible - two to the front, two to the rear.
- Each side PTO can be shifted in and out of gear independently by air or cable.
- Auxiliary power can be transmitted whilst the vehicle is in motion.
- Main drive to the rear axle is controlled by air or cable independently of PTO operation.
- Provision for electronic tachograph.

DRY WEIGHT: 9,1 kg

4.2.58.0.X.03.0.0

BASIC SERIAL NUMBER _____

SHIFTING
1 = AIR
2 = CABLE

AUXILIARY POWER TAKE-OFFs SELECTION

PTO output speed depends on selected gear in gearbox, PTO ratio, engine r.p.m.

Select the required PTO ratio and power output.

When using one only side PTO the cover kit part nr. 2.99.023.0000 must be requested to close the free aperture.

PTO	RATIO	TORQUE Kgm	ROTATION	STUD KIT
4.2.31.5.X.XX.X.X	0.956	40	ENGINE	2.05.009.0000
5.2.69.1.X.XX.X.X	1.014	25	ENGINE	2.05.117.0000
5.3.69.1.X.XX.X.X	1.503	25	ENGINE	2.05.117.0000
4.2.15.4.X.XX.X.X	1.941	20	ENGINE	2.05.121.0000
5.4.69.1.X.XX.X.X	1.833	20	ENGINE	2.05.117.0000

SECTION A-A

WITH SPICER 1410, 1500 - DIN 20 FLANGES FITTED

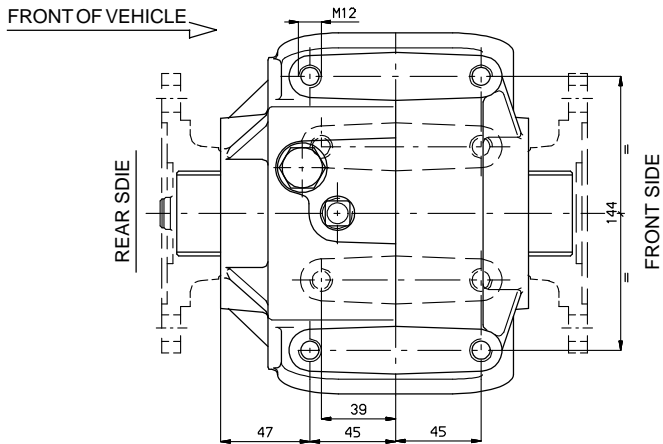
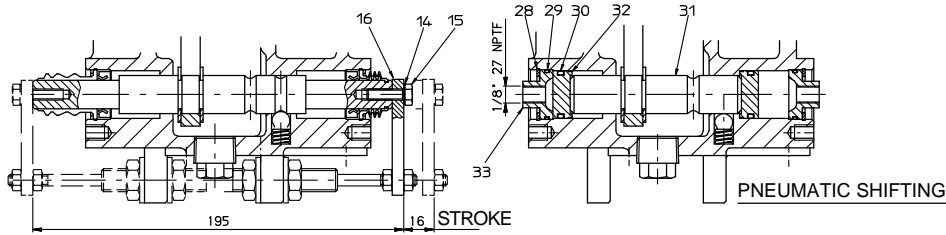
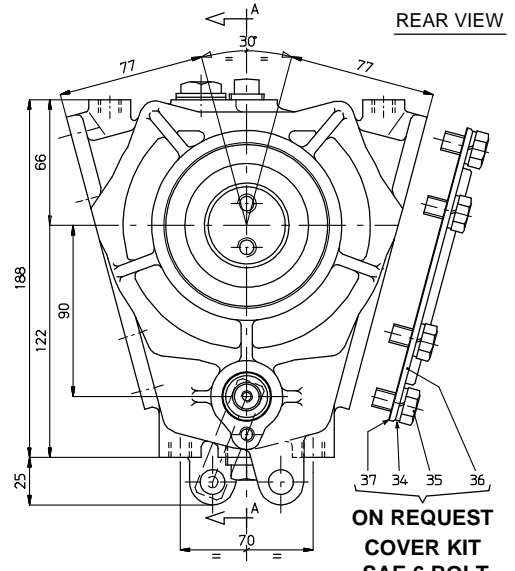
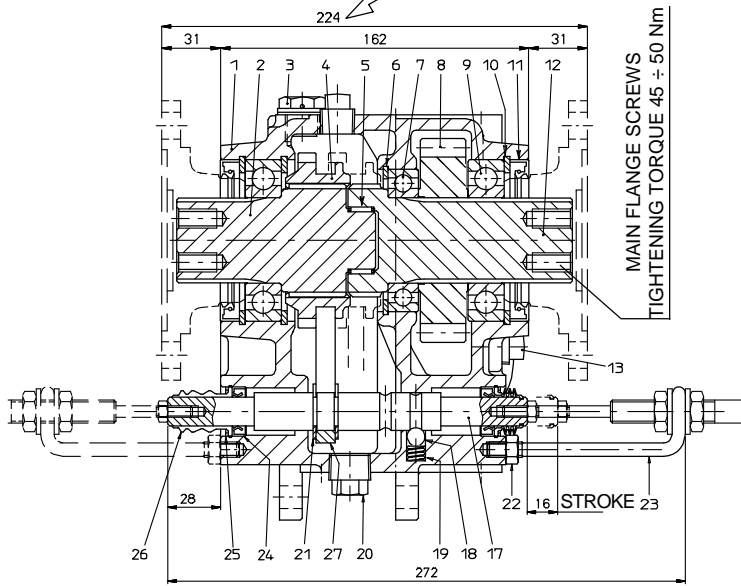

REF.	CODE	DESCRIPTION	QT.
1	1.01.05.011.00	Housing	1
2	1.13.01.158.00	Shaft	1
3	0.12.01.038.00	Filler-breather with gasket TCSF 1815	1
4	1.17.02.079.00	Splined sleeve	1
5	0.10.06.018.00	Needle cage K30x35x13	1
6	0.07.02.044.00	Circlip 75i UNI 7437	1
7	0.10.01.016.00	Bearing 6009	1
8	1.11.03.132.00	Gear 33 T	1
9	0.10.01.003.00	Bearing 6209	2
10	0.07.02.029.00	Circlip 85i UNI 7437	3
11	0.08.01.081.00	Seal 65x85x10	2
12	1.13.01.159.00	Shaft	1
13	0.12.01.049.00	Plug 18x1,5 FIAT 1/43236/11	2
14	0.04.04.004.00	Washer Schnorr 6	1
15	0.01.01.027.00	Capscrew TE M6x20 UNI 5739 CL RES 8.8	1
16	1.99.00.249.00	Extention	1
17	1.14.03.091.00	Shaft	1
18	0.11.01.002.00	Ball 3/8"	1
19	1.28.01.003.00	Coil spring mod.15/2	1
20	0.12.01.002.00	Plug M22x1,5	1

REF.	CODE	DESCRIPTION	QT.
21	0.07.03.001.00	Circlip RS15 UNI 7434	2
22	0.03.01.002.00	Hex nut M8 UNI 5588	1
23	1.99.00.111.00	Outer cable support	1
24	0.08.01.004.00	Seal 15x26x7	2
25	0.07.05.005.00	Circlip SB26	2
26	1.99.00.251.00	Rubber boot	2
27	1.22.01.051.00	Fork	1
28	0.07.02.034.00	Circlip 26i UNI 7437	2
29	0.08.02.067.00	O-Ring OR 2087	2
30	0.08.02.014.00	O-Ring OR 3081	2
31	1.14.03.076.00	Shaft	1
32	1.21.02.016.00	Piston	2
33	1.24.01.067.00	Cover	2
ON REQUEST: COVER KIT SAE 6 BOLT 2.99.023.0000			
34	0.04.02.003.00	Lockwasher 10,5 UNI 1751	6
35	0.01.01.014.00	Capscrew TE M10x30 UNI 5739	6
36	0.99.00.409.00	Cover 6 bolt SAE	1
37	1.29.01.501.00	Gasket 6F SAE sp. 0,5	1

ON REQUEST: MOUNTING BRACKET KIT CODE 2.99.197.0000

Mounting kits are available for easy installation of the 4.2.58.0 Split-Shaft Units in the truck chassis.

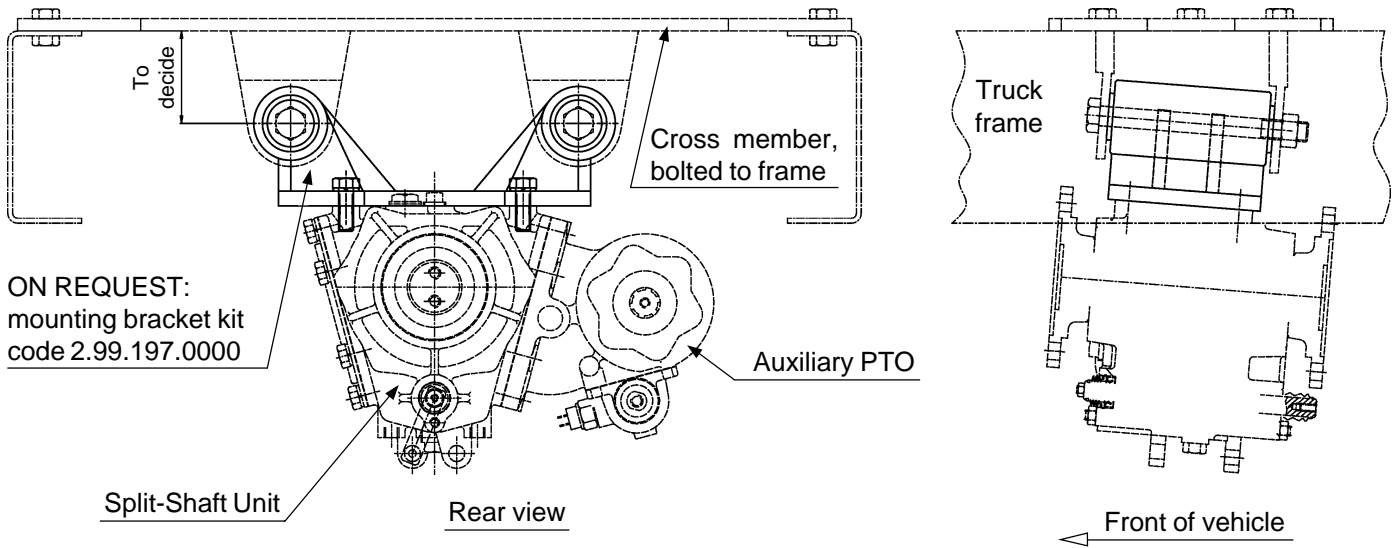

**ON REQUEST:
DOUBLE-ACTING AIR CONTROL TO CONNECT/DISCONNECT MAIN DRIVE
CODE 0.00.04.023.00**

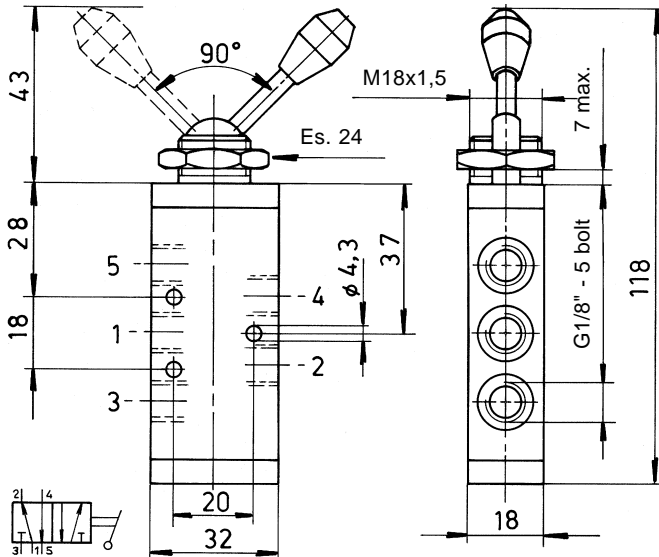

SPECIFICATIONS

Fluid:	Air, filtered and oiled
Operating pressure:	10 Bar max.
Operating temperature:	from -5°C to +70°C