



# PZB®

D01P-0-03 - Pagina WebPTO PZB - rev. 0

# 421ZF



## #PTO POS. H. D. D.U. ZF AS TRONIC

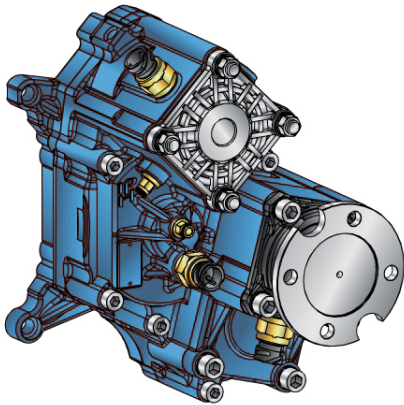

**421ZF** **XX** **Y** **K** **Z1** **Z2**

- Outlet version
- Outlet control option
- Available option
- Control option
- Model

	<b>Output 1</b>	<b>Output 2</b>	<b>Number of teeth</b>	12
<b>Torque (Nm)</b>	800	500	<b>Module</b>	3,25
<b>Int. ratio</b>	1,21	1,6	<b>Replace</b>	
<b>Number of axles</b>	2	2	<b>Replaced by</b>	

31/01/2014

### Command type

- Mechanical with lever remote control (TC)
- Hydraulic control
- Pneumatic
- Ready for electric solenoid control
- Depressure control
- Constantly engaged
- Mechanical with PUSH-PULL remote control
- Electric control KES 5
- Ready for detached control

