



PZB®

D01P-0-03 - Pagina WebPTO PZB - rev. 0

421VI



#PTO POS. H. D. D.U. VOLVO VT C

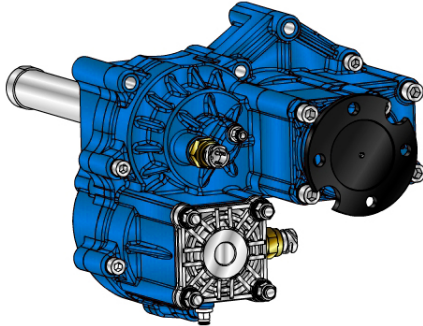

421VI XX Y K Z1 Z2

- Outlet version
- Outlet control option
- Available option
- Control option
- Model

	Output 1	Output 2	Number of teeth	12
Torque (Nm)	800	500	Module	3,25
Int. ratio	1,45	1,94	Replace	904
Number of axles	2	2	Replaced by	

31/01/2014

Command type

- | | | |
|--|---|---|
| <input type="checkbox"/> Mechanical with lever remote control (TC) | <input type="checkbox"/> Hydraulic control | <input type="checkbox"/> Pneumatic |
| <input type="checkbox"/> Ready for electric solenoid control | <input type="checkbox"/> Depressure control | <input type="checkbox"/> Constantly engaged |
| <input type="checkbox"/> Mechanical with PUSH-PULL remote control | <input type="checkbox"/> Electric control KES 5 | <input type="checkbox"/> Ready for detached control |

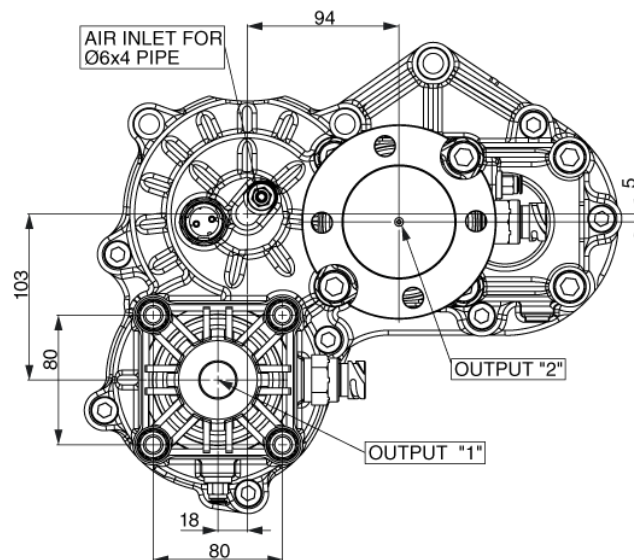
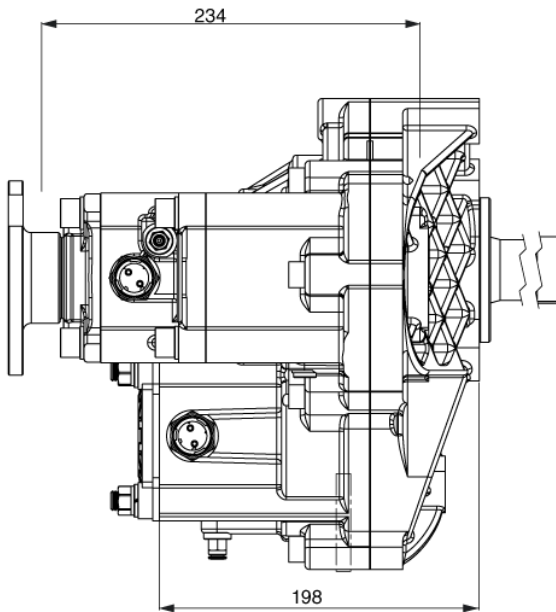

VEHICLE MOTION DIRECTION

